

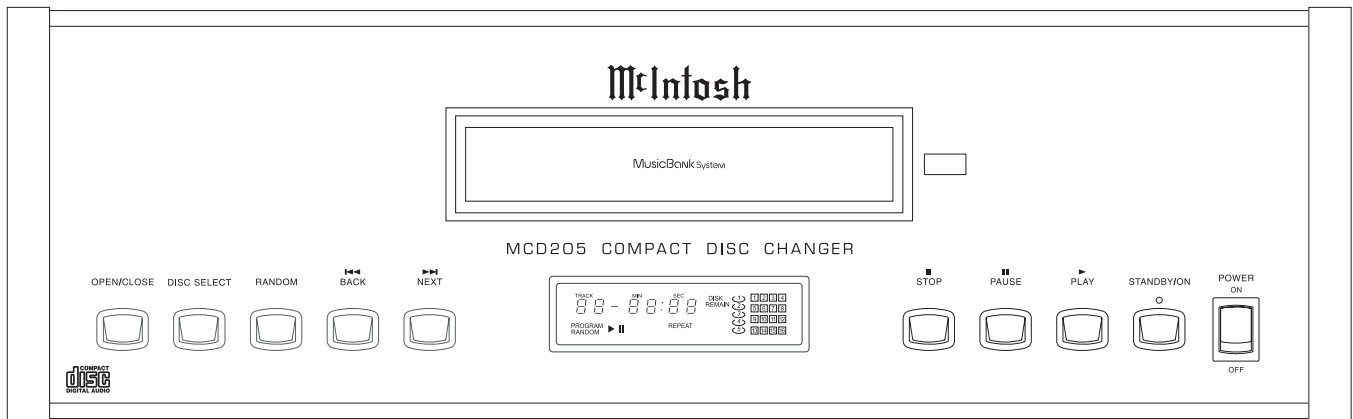

MCD205

COMPACT DISC CHANGER



CONTENTS

Performance Specifications	2	Audio/Power Schematic and PCB	7 - 12
Notes	2	Display Schematic and PCB	13 -16
Rear View and Section Location	3	Parts List	17 - 18
Block Diagram	4	Exploded View and Parts Lists	19 - 20
Interconnection Diagram	5	Repacking Instructions	21

McIntosh®

SERVICE MANUAL

PERFORMANCE SPECIFICATIONS

Frequency Response

+0, -0.5dB from 5Hz to 20,000Hz

Signal To Noise Ratio

108dB (IHF A-weighted)

Dynamic Range

100dB

Harmonic Distortion

0.002%

Channel Separation

105dB

Maximum Output Level

2.0Vrms Balanced

2.0Vrms Unbalanced

Output Impedance

600 ohms Balanced

600 ohms Unbalanced

Sampling Frequency

44,100Hz

D/A Converter

24-bit dual converters with 8 times over sampling digital filter

Error Correction

CIRC

Quantization

16-bit linear

Digital Output

Optical: -15dBm to -21dBm

Coaxial: 0.5v p-p/75 ohm

Transport Signal Readout Type

Semiconductor Optical Laser

Disc Rotational Velocity

200 to 500rpm (constant linear velocity)

Wow and Flutter

Below current measurement limits

Power Requirements

100 Volts, 50/60Hz at 25 watts

110 Volts, 50/60Hz at 25 watts

120 Volts, 50/60Hz at 25 watts

220 Volts, 50/60Hz at 25 watts

230 Volts, 50/60Hz at 25 watts

240 Volts, 50/60Hz at 25 watts

Note Refer to the rear panel of the MCD205 for the correct voltage.

Dimensions

Front Panel: 17-1/2 inches (44.5cm) wide, 5-3/8 inches (13.7cm) high. Depth behind front mounting panel is 15 inches (38.1cm) including clearance for connectors. Panel clearance required in front of mounting panel is 3/4 inch (1.9cm).

Note When a CD Disc is inserted or ejected, the panel clearance required in front of mounting panel is 3-3/4 inches (9.5cm).

Weight

21 pounds (9.5kg) net, 35 pounds (15.9kg) in shipping carton

NOTES

1. The heavy notes on the schematic denote the primary signal path.
2. Unless otherwise noted, all voltages indicated on the schematics are measured under the following conditions:
 - a. AC input at 120 volts, 50/60Hz.
 - b. All voltages are +/-10% with respect to ground. A high impedance (10 megaohm) voltmeter must be used.
3. Unless otherwise specified:
 - a. Resistor values are in ohms.
 - b. Capacitor values are microfarads (uF).
 - c. Inductor values are in microhenries (uH).
4. On PC board drawings, Square pad indicates:
 - a. Polarized Capacitors - Positive
 - b. Diodes - Cathode
 - c. Others - Pin 1
5. **WARNING**
Parts marked with the symbol  have critical characteristics. Use only replacement parts recommended by the manufacturer.

MusicBank™ is a registered trademark of the Nakamichi Corporation

REAR VIEW

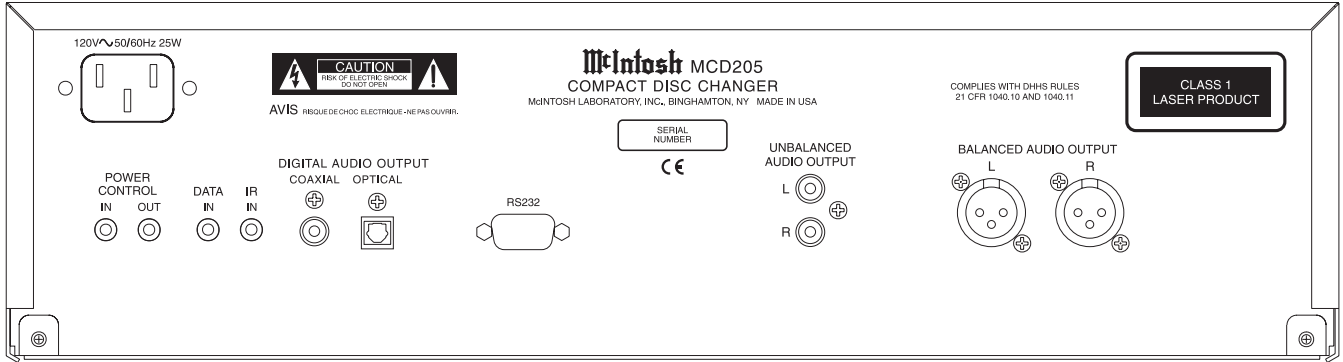

SECTION LOCATION

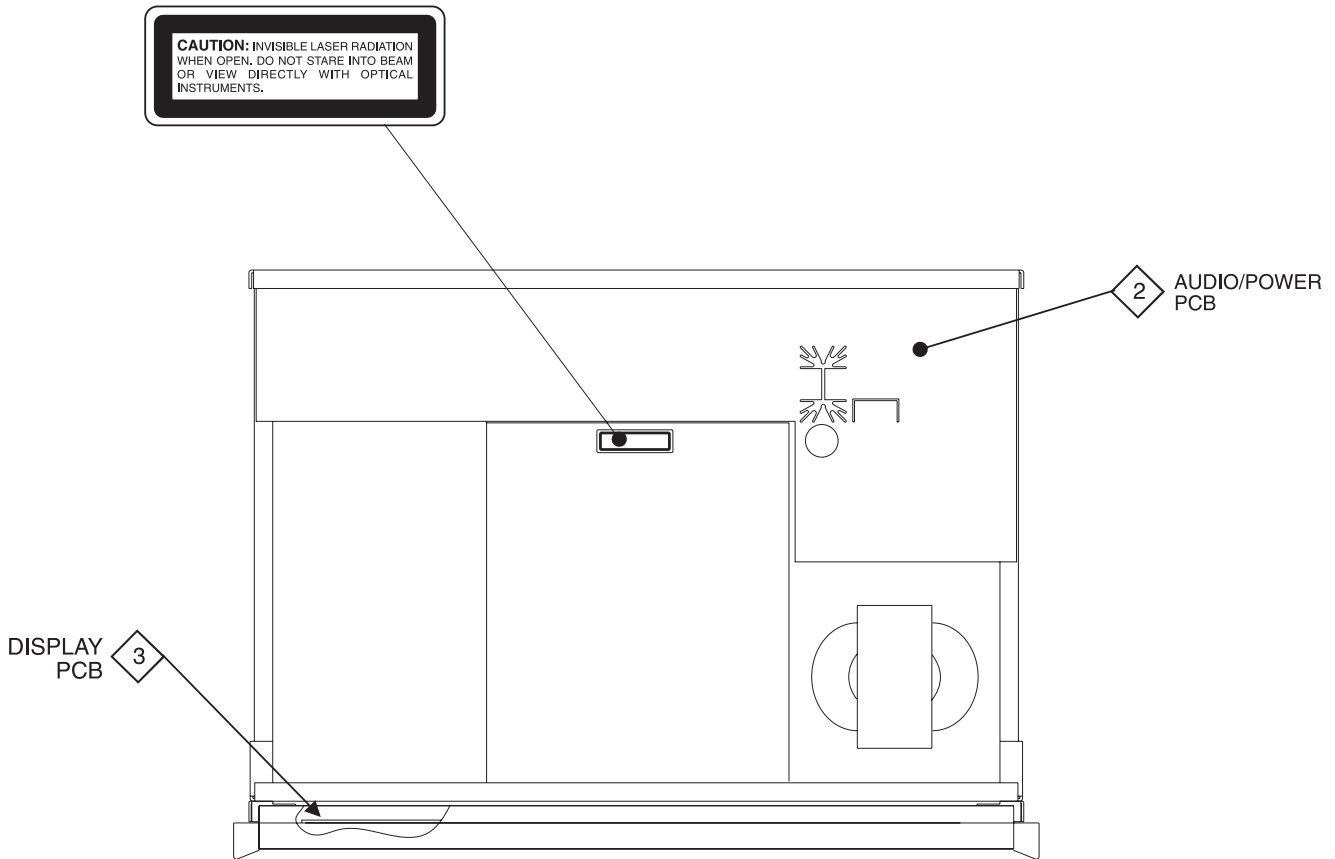

TOP VIEW WITH COVER REMOVED

BLOCK DIAGRAM

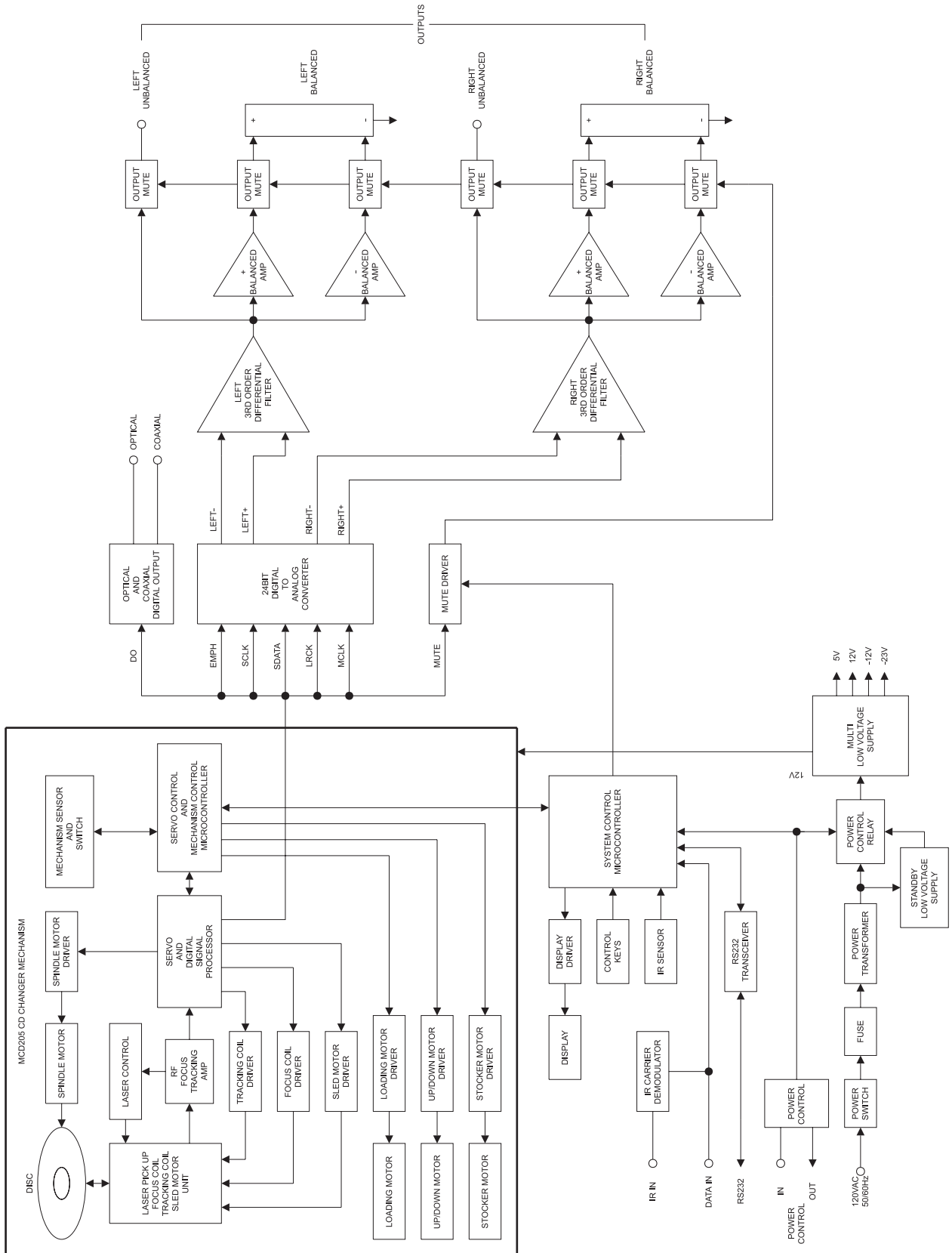

1 INTERCONNECT

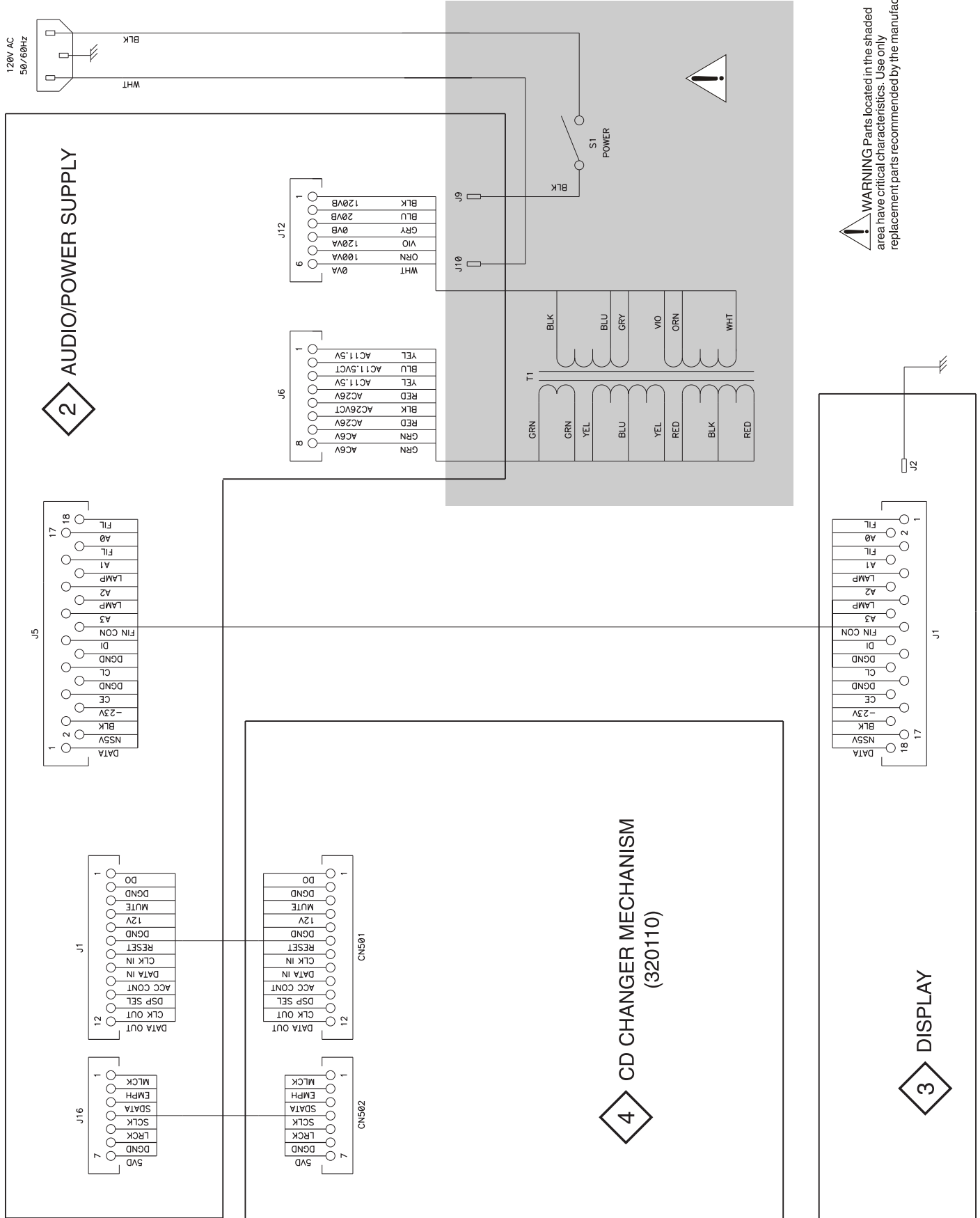

NOTES

2 AUDIO/POWER 049730 SH 1 OF 2

WARNING Parts located in the shaded area have critical characteristics. Use only replacement parts recommended by the manufacturer.

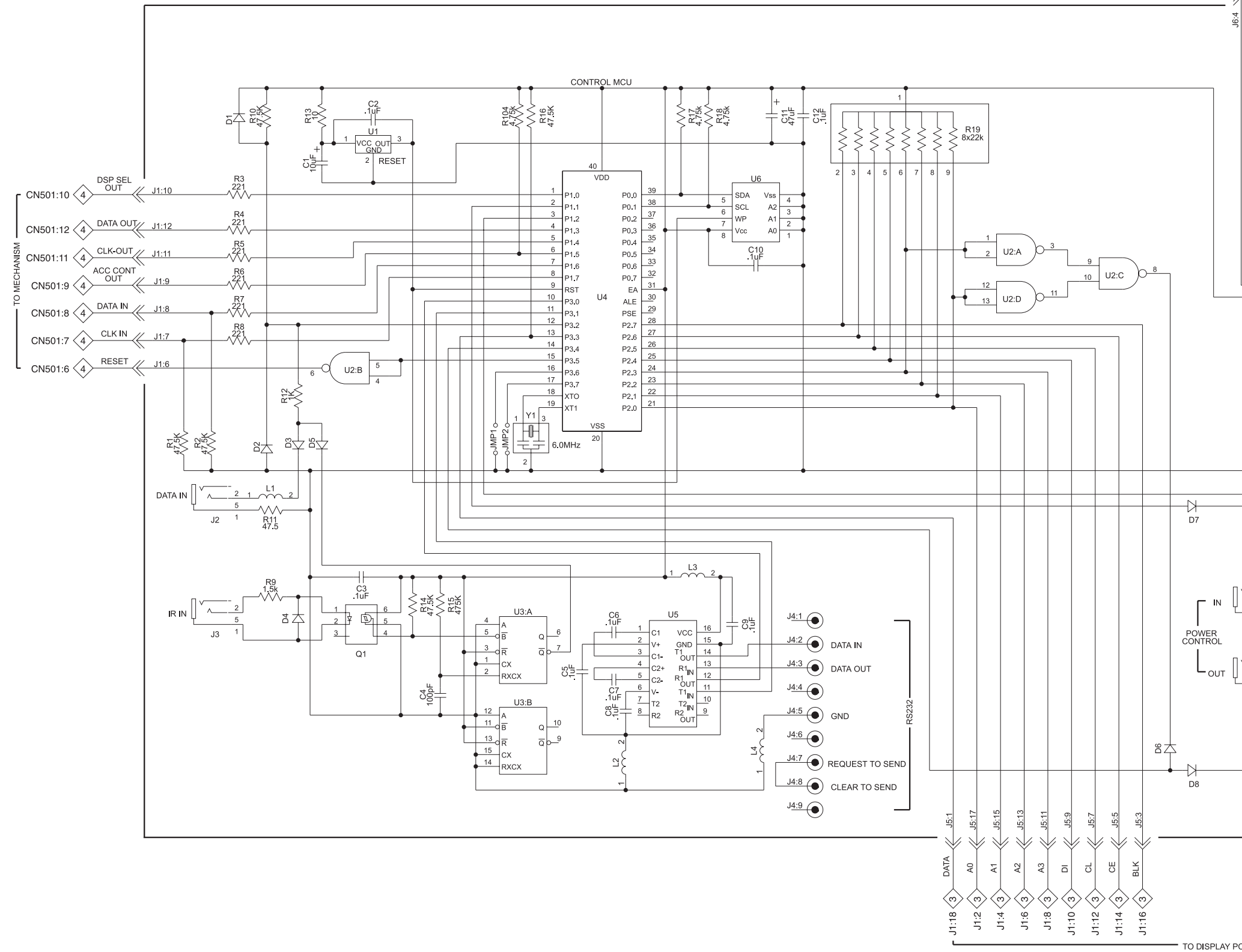

ed
ufacturer.

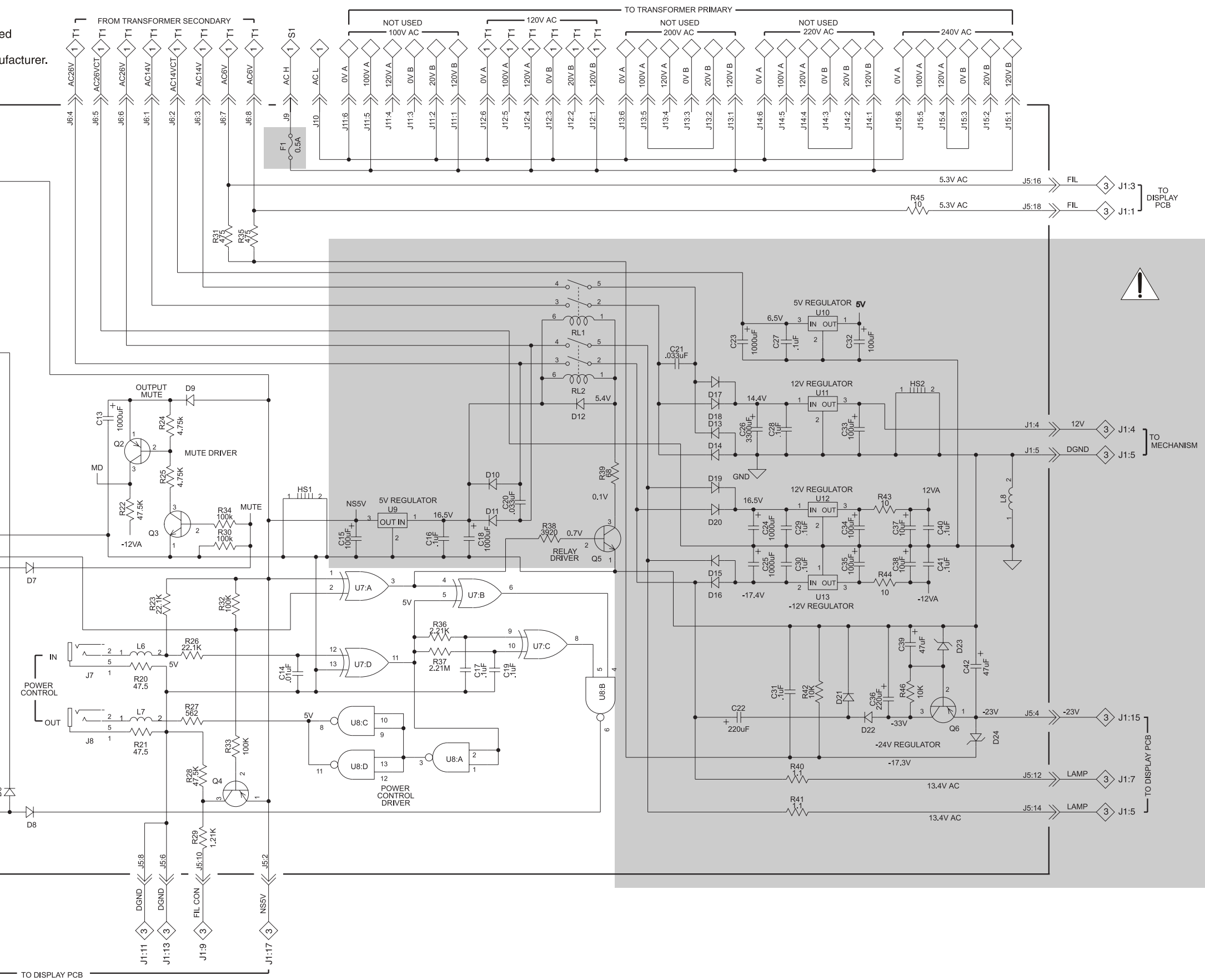

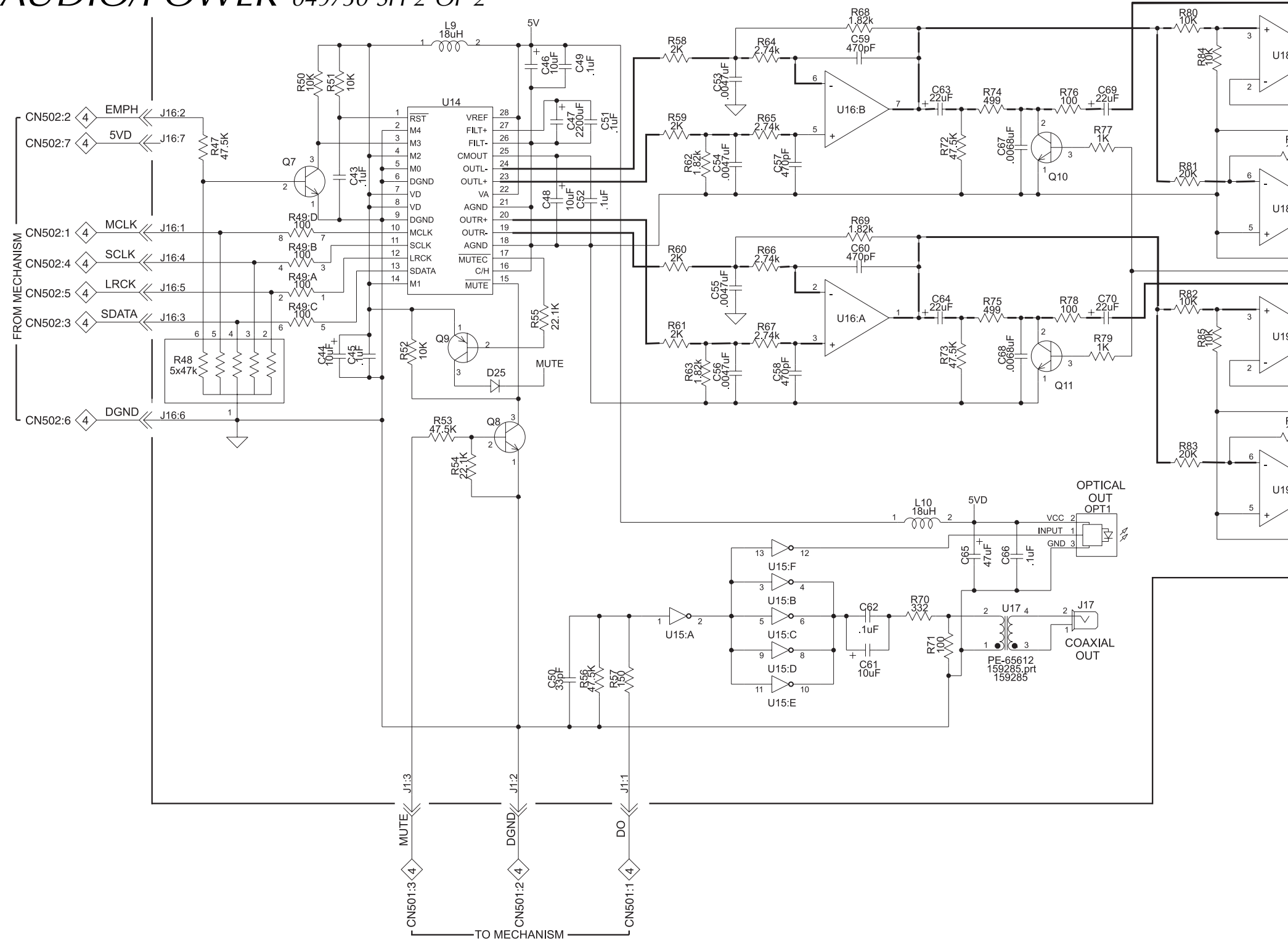

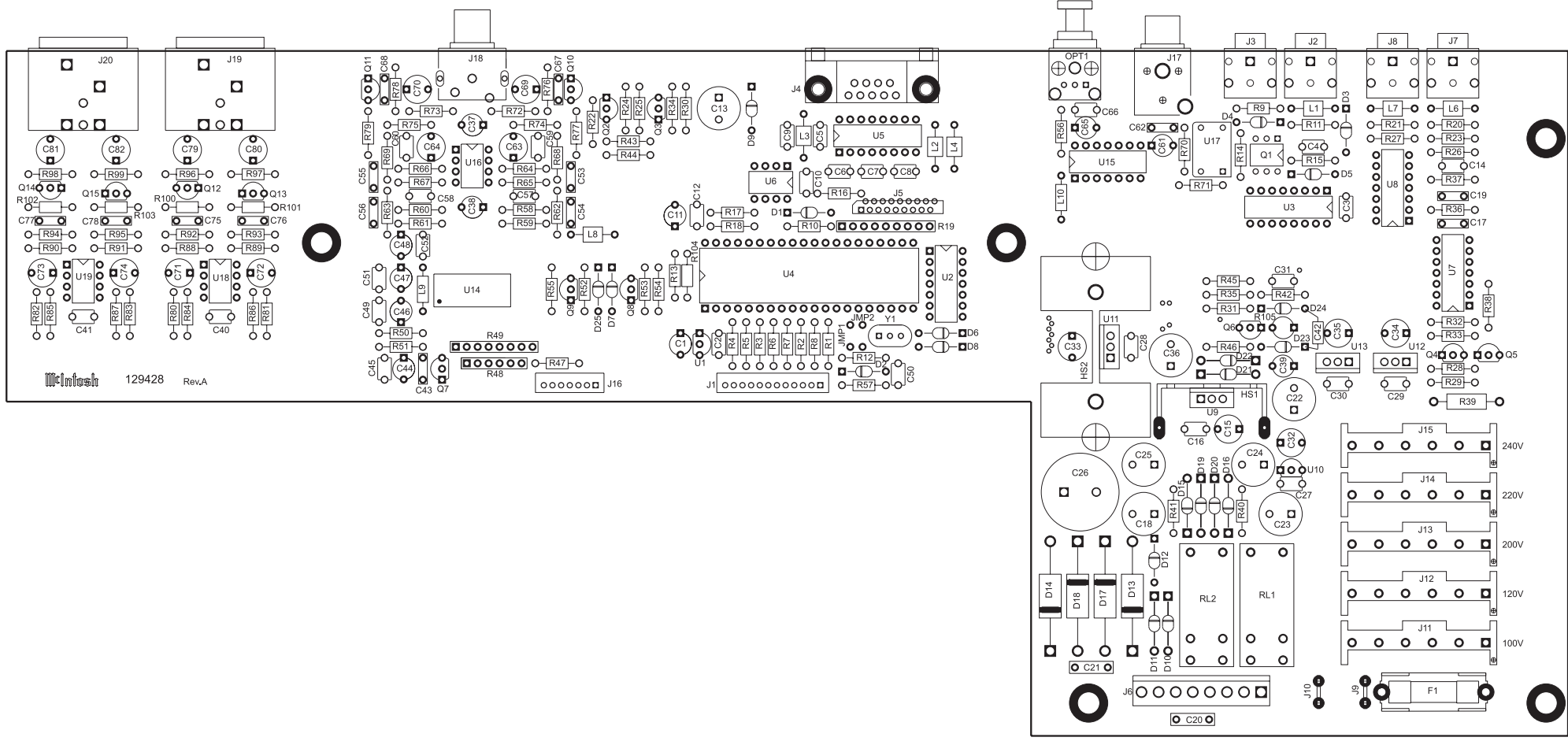
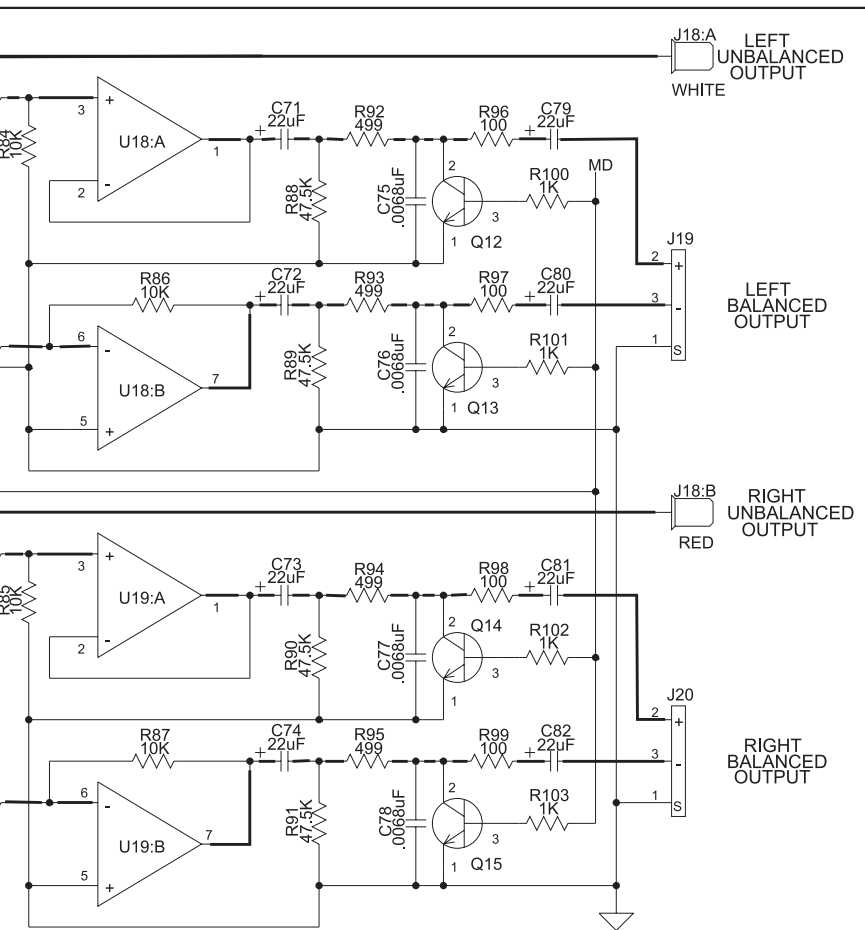

EXPLODED VIEW and PARTS LIST

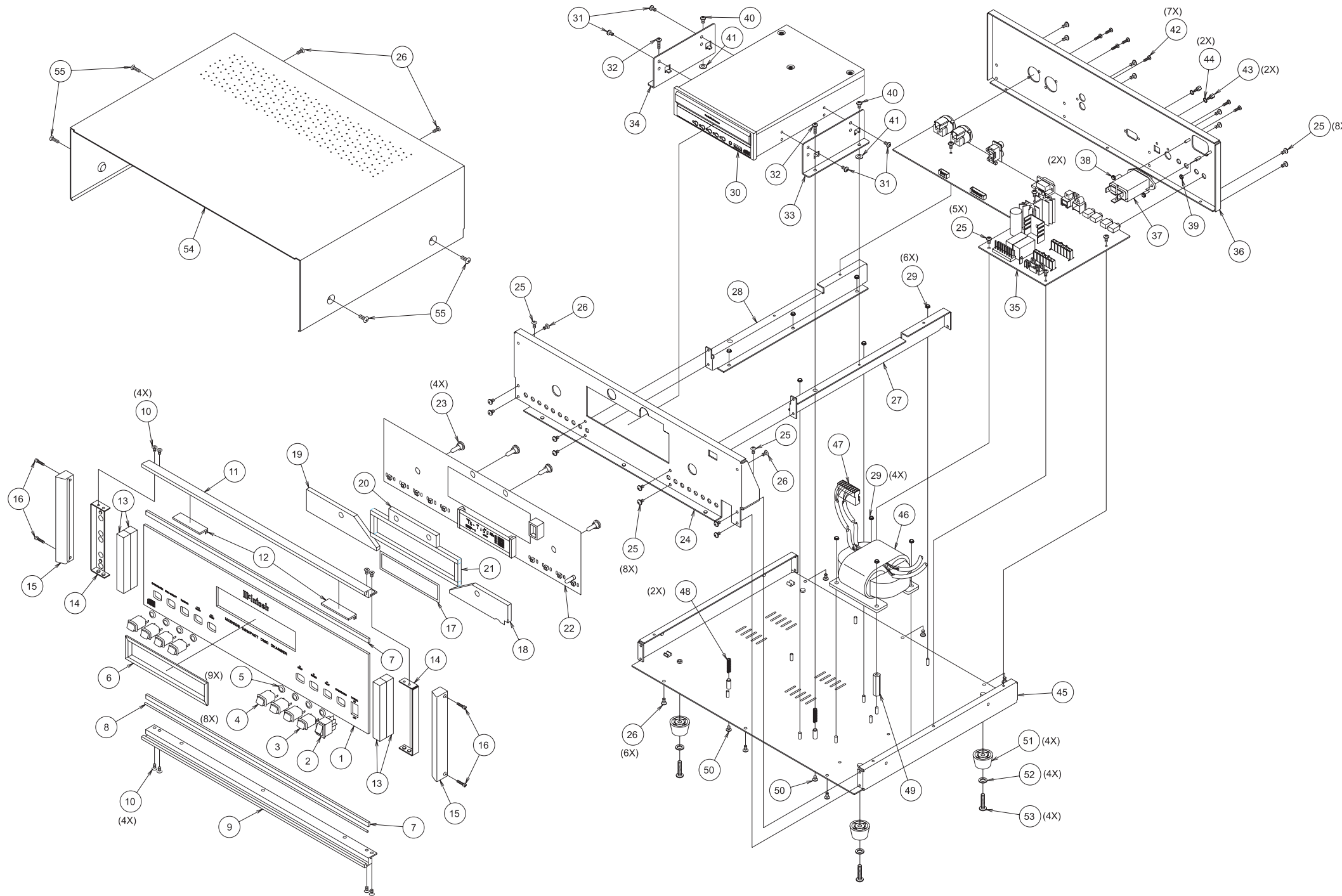

Ref No.	Part No.	Description
1	016468	GLASS
2	148073	SWITCH DPDT ROCKER
3	017531	PUSHBUTTON ASSY RED
4	017517	PUSHBUTTON ASSY BLK
5	078033	O-RING
6	017879	BEZEL GLASS
7	094016	TAPE FOAM 1/4 X 1/8
8	098113	CORD DIAL .027 BLACK BRAID SILK
9	018588	EXTRUSION BOTTOM
10	100147	SCREW MACHINE 6-32 X 3/16 PHIL
11	018585	EXTRUSION TOP
12	017798	GUIDES PRINTED CIRCUIT
13	094360	TAPE FOAM 1/2 X 1/2
14	005090	BRACKET EXTRUSION
15	018611	ENDCAP 5"
16	101042	SCREW TS 4-40 X 1/2 SLOT FILLISTER
17	092419	FILTER DISPLAY
18	017885	PLEXIGLAS DISPLAY RIGHT
19	017892	PLEXIGLAS DISPLAY LEFT
20	017886	PLEXIGLAS LOGO
21	094017	TAPE FOAM 1/4 X 1/4
22	049731	ASSY PCB DISPLAY
23	058153	LAMP INCANDESCENT
24	005224	SUBPANEL
25	101196	SCREW TAP SEMS 6-32 X 1/4 PH PN
26	101054	SCREW TAPTITE 6-32 X 1/4 PH PN
27	005222	ZEE BRACKET RIGHT
28	005223	ZEE BRACKET LEFT
29	102003	NUT MACHINE 6-32 W/LOCK
30	320110	5 DISC CD CHANGER
31	310330	METRIC SCREWS MCD205 CHANGER
32	100300	SCREW MACH SEMS 6-32 X 1 PH PN
33	005228	BRACKET MOUNTING RIGHT
34	005229	BRACKET MOUNTING LEFT
35	049730	ASSY PCB AUDIO-POWER
36	005227	REAR PANEL
37	117755	RECEPTACLE INPUT & LINE FILTER
38	102001	NUT KEP 4-40 CADMIUM PLATE
39	102020	NUT 6-32 SELF-LOCK
40	100271	SCREW SEMS 6-32 X 1/4 PH PN
41	104005	WASHER FLAT STEEL 6 X 3/8 X .032
42	101197	SCREW HI/LO 4-24 X 3/8 PH RD BLK
43	112015	STANDOFF
44	104142	WASHER LOCK 2.5mm INT STAR ZINC
45	005226	CHASSIS
46	159334	TRANSFORMER R-CORE POWER
47	117800	MTA CONNECTOR 8 PIN .156
48	019058	SPRING
49	112083	STANDOFF 6-32 X 1.250
50	100180	SCREW 6-32 X 1/8 PH PN
51	017218	FOOT PLASTIC BLACK
52	104083	WASHER #10 PLATED
53	100159	SCREW MACH 10-32 X 3/4 PH PN BLK
54	005102	COVER TOP
55	101078	SCREW TAP 8-32 X 5/16 PH PN BLK

REPACKING INSTRUCTION

In the event it is necessary to repack the unit for shipment, the unit must be packed exactly as shown below.

IMPORTANT - The four plastic feet must be attached to the bottom of the unit so they will locate in the four holes of the bottom pad. Failure to do this will result in shipping damage.

If a shipping carton or any of the interior parts is needed, please call or write the Customer Service Department of McIntosh Laboratory. Order parts from the accompanying list by part number.

Use the original shipping carton and interior parts only if they are in good serviceable condition.

Qty.	Part No.	Description
1	034075	Shipping carton only
4	033837	Foam end cap
1	034076	Inside carton only
1	033726	Top pad
1	034036	Bottom pad
1	034077	Inner carton pad
4	017218	Plastic foot
4	100159	#10-32 x 3/4" Machine screw
4	104083	#10 x 7/16" Flat washer
1	049270	Shipping carton complete with all the above parts.

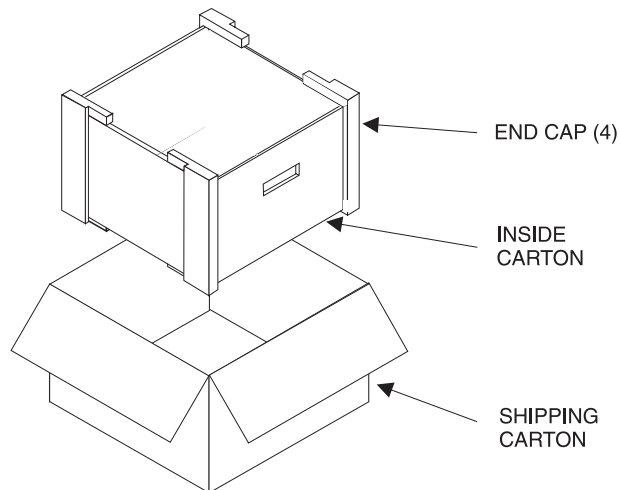
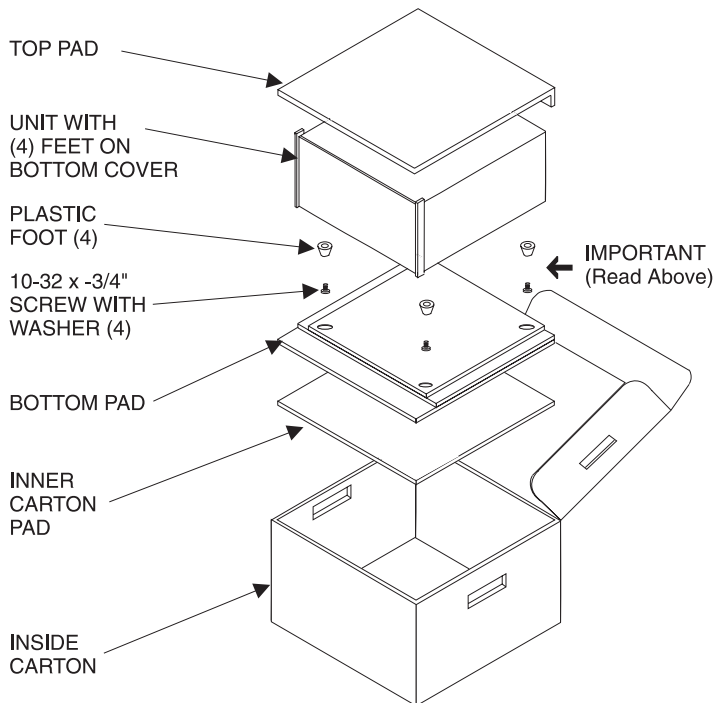

MCD205

COMPACT DISC CHANGER

SERVICE MANUAL



The continuous improvement of its products is the policy of McIntosh Laboratory Incorporated, who reserve the right to improve design without notice. Because of the constant upgrading of McIntosh products' circuitry and components, the Company cannot insure, and does not warrant, the accuracy of the within schematic material, which is intended for information only.